

## Caratteristiche tecniche / Technical details

<b>Combustibile consigliato</b> <i>Recommended fuel</i>	Ciocchi, potature <i>Logs, trimmings</i>
<b>Consumo medio</b> <i>Average fuel consumption</i>	7,5 kg/h 16,5 lbs/h
<b>Carica nominale</b> <i>Rated charge</i>	8,3 kg/h 18,3 lbs/h
<b>Dim. piano forno</b> <i>Oven floor dim.</i>	120x100x7,8 cm 47,6 x 39,7 x 3,1 in
<b>Area piano forno</b> <i>Oven floor area</i>	1,20 m <sup>2</sup> 12,9 ft <sup>2</sup>
<b>Peso forno / peso con base</b> <i>Oven weight / oven + base</i>	355 / 450 kg 781 / 990 lbs
<b>Temperatura massima</b> <i>Max oven temperature</i>	450°C 752°F
<b>Minuti per scaldare</b> <i>Heating time</i>	40
<b>N° pizze alla volta</b> <i>Pizza capacity</i>	8
<b>Infornata di pane</b> <i>Bread capacity</i>	14 kg 30,8 lbs
<b>Tiraggio minimo</b> <i>Minimum flue draught</i>	11 Pa
<b>Flusso volumetrico fumi</b> <i>Flue smokes mass flow</i>	49,6 g/s
<b>Emissioni CO al 13% O<sub>2</sub></b> <i>CO emission at 13% O<sub>2</sub></i>	0,35 % 4444 mg/Nm <sup>3</sup>
<b>Temperatura fumi</b> <i>Smoke temperature</i>	387°C 728,6°F
<b>Colore</b> <i>Color</i>	Verde siderale <i>Sideral green</i> 



## Materiali utilizzati / Used material:

lamiera ferro, acciaio inox, fibra ceramica  
*sheet iron, stainless steel, ceramic fiber*

## Tipo di refrattario / Type of refractory:

tavella silico-alluminoso  
*tile silico-alluminoso*

## Misure / Dimensions

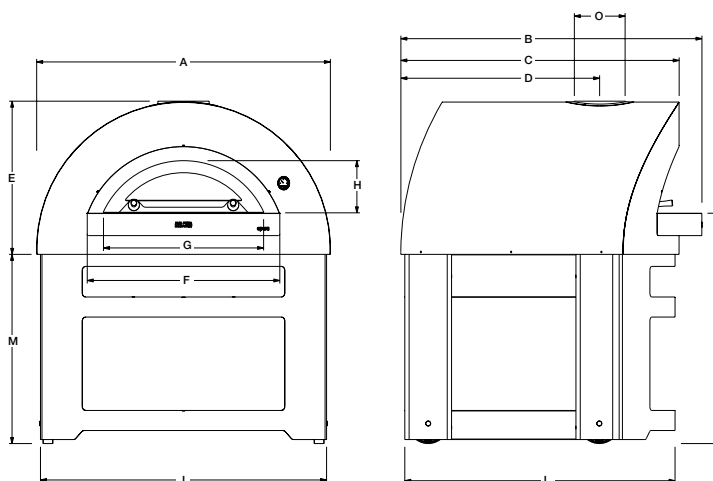

<b>A</b>	146 cm / 57 in	<b>B</b>	150 cm / 59 in	<b>C</b>	139 cm / 54 in
<b>D</b>	99 cm / 38 in	<b>E</b>	76 cm / 30 in	<b>F</b>	96 cm / 38 in
<b>G</b>	77 cm / 30,3 in	<b>H</b>	24,5 cm / 9,6 in	<b>I</b>	142 cm / 56 in
<b>L</b>	135 cm / 53 in	<b>M</b>	94 cm / 37 in	<b>N</b>	115 cm / 45 in
<b>O</b>	25 cm / 10 in				

## Componenti / Parts list

	<b>CODICE</b>	<b>N°</b>	<b>DESCRIZIONE</b>
a	XCMOPE	1	Camera Forno
b	XPROPE	1	Piano Refrattario
c	YSPOOPE	1	Sportello
d	ADDOPE	1	Davanzale
e	XCSOPE	1	Corpo struttura
f	YT19063	1	Termometro
g	FBA-OPERA	1	Base (*)

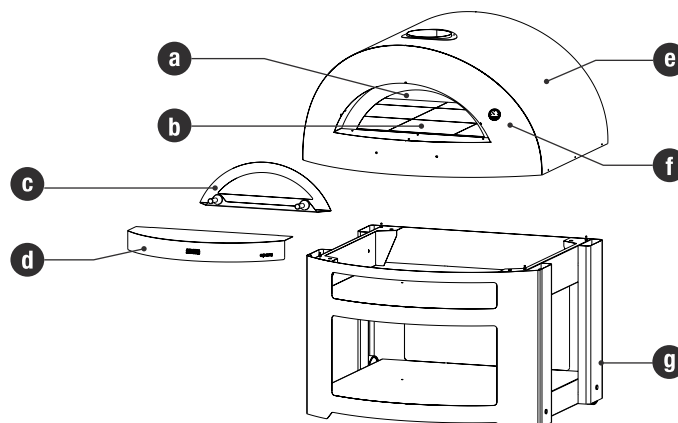

(\*): Opera viene fornito senza base, la base del forno è fornita separatamente.

(\*): Opera is not equipped with the base, the base can also be purchased separately.